

Winch type OAW 6.5 GP10

Products

A range of compact lifting and pulling air winches specially designed for offshore applications or for any other hazardous environment where space is limited. The heavy duty planetary gearbox is mounted within the drum core, which both saves space and protects from any external damage. Winches designed to meet independent third party requirements such as Lloyds, ABS, etc.

| | |
|-------------------------------|--------------|
| Manufacturer code | OAW 6.5 GP10 |
| Medium | Pneumatic |
| Environment | Oil and Gas |
| Application | Pulling |
| Series | OAW |
| Working Load Limit (WLL) [kg] | 9180 kg |
| Number of layers | 5 |
| Lifting WLL first layer | 9180 kg |
| Lifting WLL top layer | 6500 kg |
| Speed at first layer | 7 m/min |
| Speed top layer | 14 m/min |
| Drum capacity top layer | 209 m |
| Rope diameter | 22 mm |
| Mass | 1180 kg |
| Flow | 300 L/sec |
| Pressure drop | 7 bar |

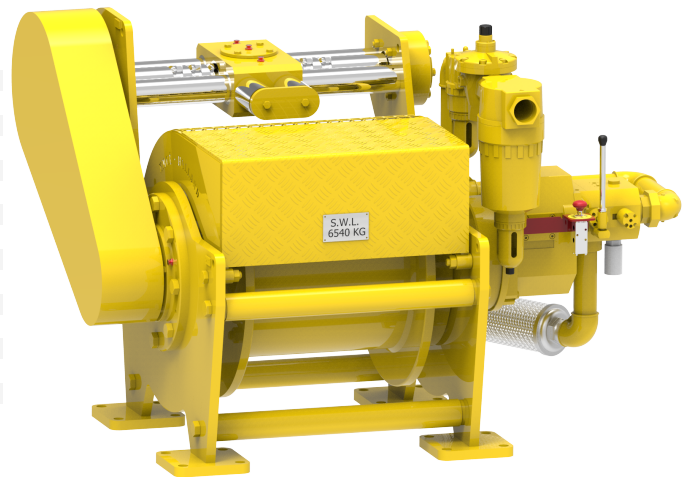

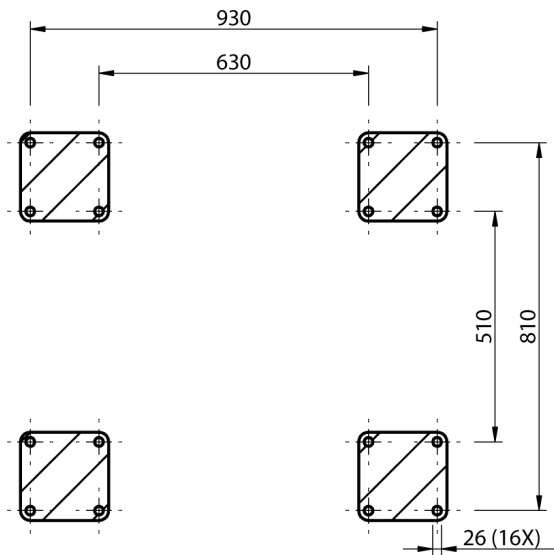
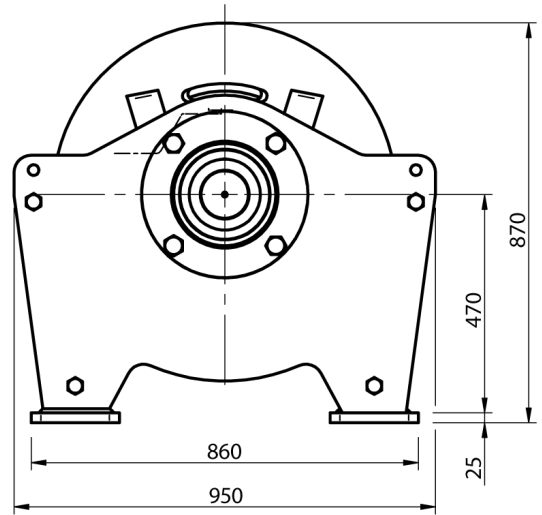
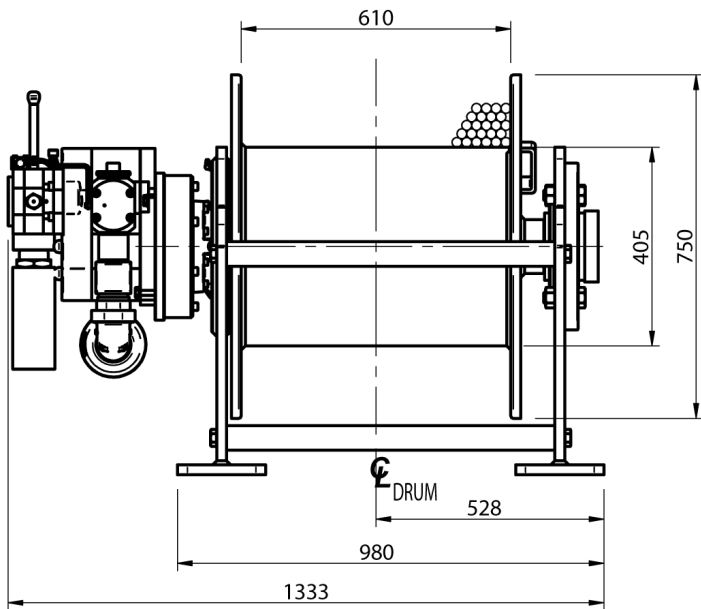

FOOTPRINT TOP VIEW - A-A