

Winch type SC 110 H

Products

A range of compact lifting and pulling winches utilising electric or hydraulic motors. The heavy duty planetary gearbox is located within the drum core, which both saves space and protects the gearbox from any external mechanical threats. Capacities can go up to 30 tons of lifting capacity with this range. Depending on your power source and application, we can select and offer the correct model for you.

Manufacturer code	SC 110 H
Medium	Hydraulic
Environment	Oil and Gas
Application	Pulling
Series	SC
Working Load Limit (WLL) [kg]	15910 kg
Number of layers	5
Lifting WLL first layer	15910 kg
Lifting WLL top layer	11000 kg
Speed at first layer	10 m/min
Speed top layer	14 m/min
Drum capacity top layer	228 m
Rope diameter	30 mm
Mass	1675 kg
Flow	120 L/min
Pressure drop	220 bar

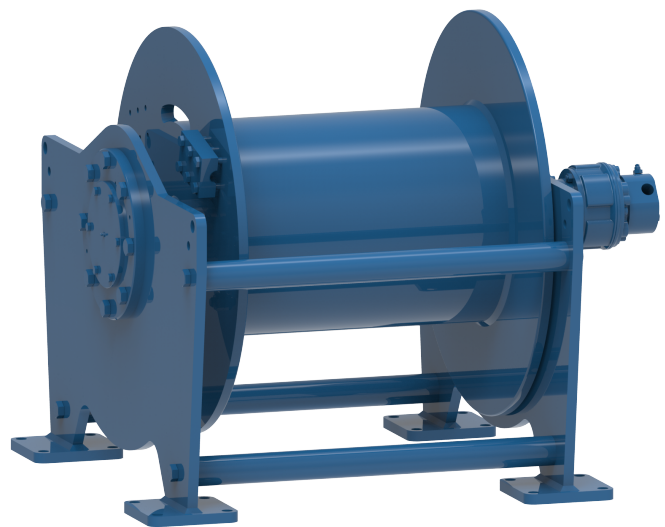

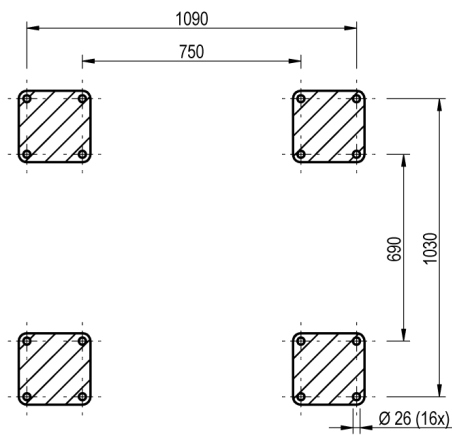
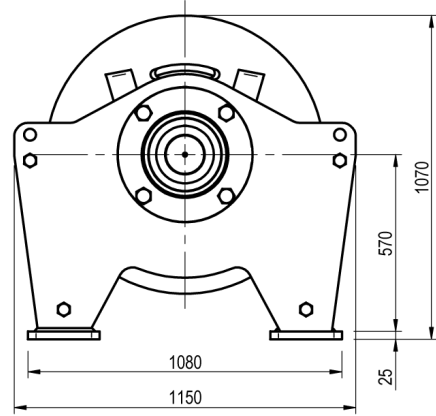
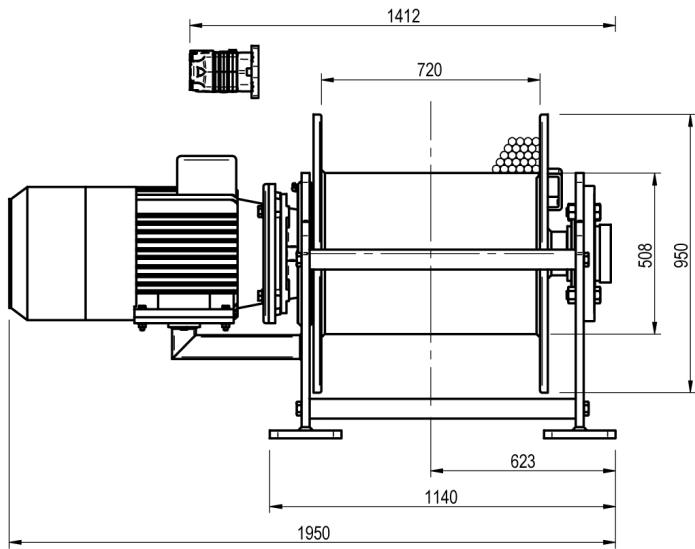

FOOTPRINT TOPVIEW A - A

