

Every winch  
a winner

**EMCÉ**

Winches | Stokvis Group

## Introduction

Founded on over 75 years of manufacturing excellence, EMCÉ has grown to become one of the world's most respected producers of high quality, high performance winches, capstans and hoisting equipment. Although we continue to design a wide variety of products for the fishing, shipbuilding and civil engineering industries, our output has expanded to include bespoke solutions for the offshore oil and gas industry. EMCÉ winches are now found on vessels, installations and drilling rigs the world over.

EMCÉ not only designs, engineers and manufactures winches and related equipment, but also provides professional advice and design through the procurement, engineering, testing, delivery and installation phases of projects, as well as in the inspection, repair and maintenance of our products.



## Simple solutions - powerful products

Over the last 30 years, EMCÉ has delivered more than 30,000 winches with a range of operating parameters, engineering configurations and auxiliary functions. Through our international dealership network, we supply simple, reliable, efficient equipment and tailored solutions to suit any performance criteria and application. This allows us to optimise the functionality, reliability and overall simplicity of every product.

Approximately 75% of our output is designed to order, with the remainder residing in our extensive stock inventory. We can also design and engineer the structural foundations, mounting and housing requirements for our equipment, in co-operation with our clients.

Three-quarters of a century of experience goes into the making of every EMCÉ product - and we're proud of the fact.

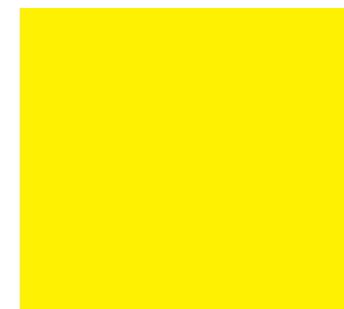

# Every wish is our command

We think, we make, we lift



# Every detail adds up to performance

Quality, material and smart construction

## Product range

### Winches

We produce standard worm-gear and planetary-driven winches for lifting, pulling, man-riding, mooring and anchoring. They range from 100 kg to 100 tons and are electrically, hydraulically or pneumatically driven.

### Capstans

We provide rugged, self-contained worm gear or planetary capstan systems with electric, hydraulic or pneumatic transmission. All capstans can be ATEX-rated, where required. We can also equip capstans with watertight or drip-waterproof motors and self-aligning mounting plates for high static loads.

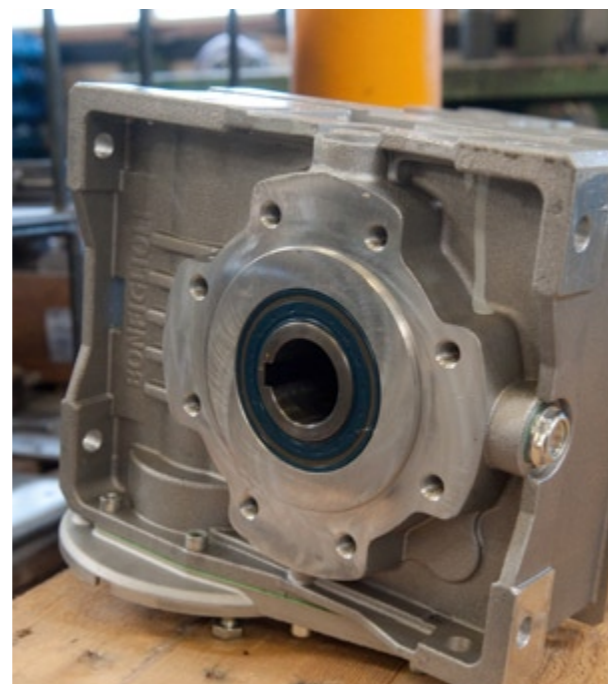

### Hose Reels

We produce hose reels ranging from 1 to 8 inches in diameter and up to 4 metres flange size for both onshore and offshore applications, typically heavy lift vessels, semi-subs, DSVs, re-search vessels, cable and pipe laying vessels and offshore pile-driving barges.

### Projects

EMCÉ has developed a Diving Launch and Recovery System - the DLR 1250 - which is used for offshore diving applications to 90 meters. Fully compliant, compact and robust, it is available for sale or lease.

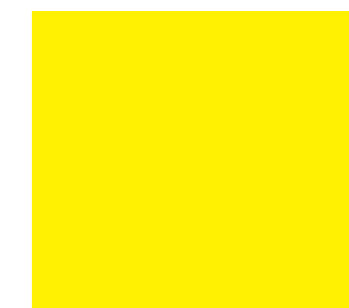

### Service & Repair

Nobody knows EMCÉ's winches better than EMCÉ. Our specialist teams of trained experts are the best people to conduct in-house and on-site inspection, repair and maintenance work and our supplier network stocks the full complement of replacement parts for rapid repair, when required.



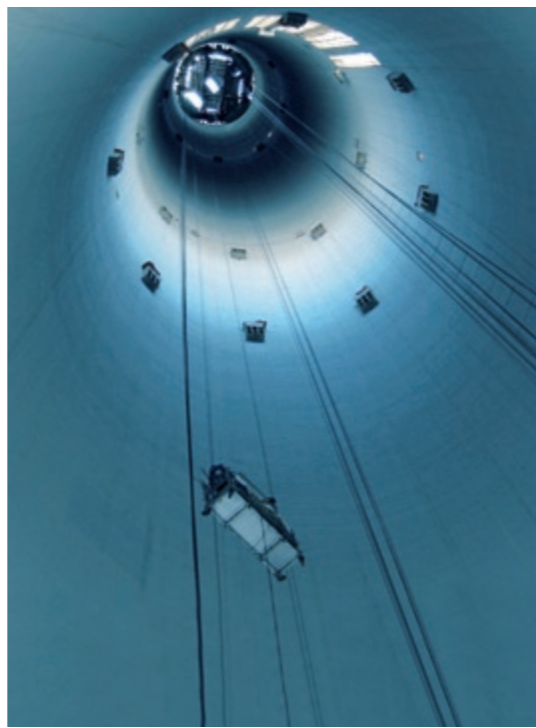

### Our mission & values

EMCÉ's mission is to exceed the quality, performance, durability and safety expectations of our customers, whether in shipbuilding, oil and gas, dredging, fishing, construction, mining, theatre or general industry.

Our core values are focused on maintaining the highest quality standards through our products, personnel and services. We understand the importance of ensuring that solutions meet or exceed the expectations placed upon them. We actively pursue ways of delivering this assurance, through open and honest dialogue, transparent operational procedures, rigorous testing and full certification.

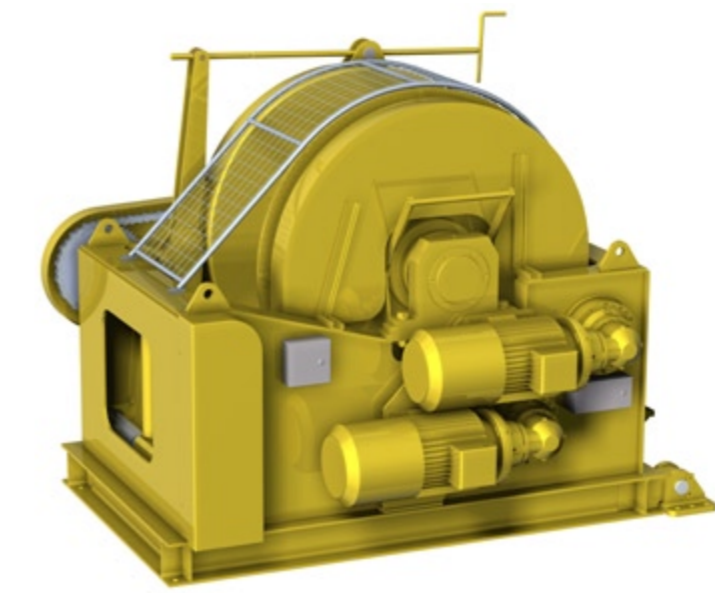

Tugger winch  
OAW 5.0 GP16



Tugger winch  
OAW 5.0 GP16



Manriding winch  
MR 30 FLG



Manriding winch  
MR 30 FLG



Monkey board winch  
FD 303 GP2



Monkey board winch  
FD 303 GP2



Driver launch and  
recovery winch - OHR 3.0



Driver launch and  
recovery winch - OHR 3.0



BOP handling winch  
OAW 7.0 GP16



BOP handling winch  
OAW 7.0 GP16



Mooring winch  
SR 20 EBCS



Mooring winch  
SR 20 EBCS

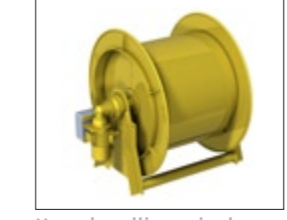

Hose handling winch  
SB 307R E



Hose handling winch  
SB 307R E

# Every task in all conditions

Building for industry, oil & gas, shipping and construction

### QHSE

The design, fabrication and testing of all EMCÉ's products is conducted in-house, guaranteeing that the highest standards of design, engineering, workmanship and finishing are maintained at all times. We oversee every stage of the process, checking and verifying that nothing is left to chance. Safety is the critical element in most of our product applications and we insist on rigorous QHSE processes and standard industry certification to clearly demonstrate this commitment.



### About winches

Ex enit in utat dolum autat. Em dolorerosto od doloreet nit alit lorperiurem dolese dolorem iriliquat, quis nos dolobor aciduis augiam aci etum exercidunt praestrud ming ex ea feu feu faccum velit velit dolor am irilluptat vel ea faciliq uipsum quate euguer augiat. Ut alit iuscill.



# Delivery program



Loosterweg 7  
2215 TL Voorhout  
Tel: +31 (0)252 219123  
Fax: +31 (0)252 231660  
Email: info@stokvis.eu  
www.stokvis.eu

## Winches

The logo for EMCÉ, with the letters in a bold, blue, sans-serif font.

Winches | Stokvis Group

[www.emce.com](http://www.emce.com)

## Automotive

The logo for WIEGEL, with the letters in a bold, orange, sans-serif font.

Transport Equipment | Stokvis Group

[www.wiegel.nl](http://www.wiegel.nl)

## Transmissions

The logo for elsto, with the letters in a blue, lowercase, sans-serif font.

aandrijftechniek | Stokvis Group

[www.elsto.nl](http://www.elsto.nl)

The logo for STOLK, with the letters in a bold, black, sans-serif font, underlined.

Transmission Services | Stokvis Group

[www.stolkservices.nl](http://www.stolkservices.nl)

The logo for boekholt, with the letters in a blue, lowercase, sans-serif font.

aandrijftechniek | Stokvis Group

## Lifting & Handling

The logo for EBD, with the letters in a bold, black, sans-serif font, enclosed in a blue rectangular border.

Techniek | Stokvis Group

[www.ebdtechniek.nl](http://www.ebdtechniek.nl)

## The benefits of using EMCÉ

**Quality** – it underpins everything that we do and we never compromise on it.

**Standards** - they govern the design and fabrication of every EMCÉ product.

**Expertise** – translates into invaluable insight and understanding.

**Innovation** - pioneering high performance, low-maintenance solutions.

**Flexibility** - through countless operational configurations to suit every application.

**Bespoke Solutions** - designed to meet your specific operating and performance criteria.

**In-house Capability** – giving us complete control of time, quality and resource provision.

**Rapid Response** – to speed up turnaround times, even on complex projects.

**Location** – ideally placed for international distribution, and with a global support network.

**Price** – not just of the product, but of its 'total cost of ownership'. This is where we excel.



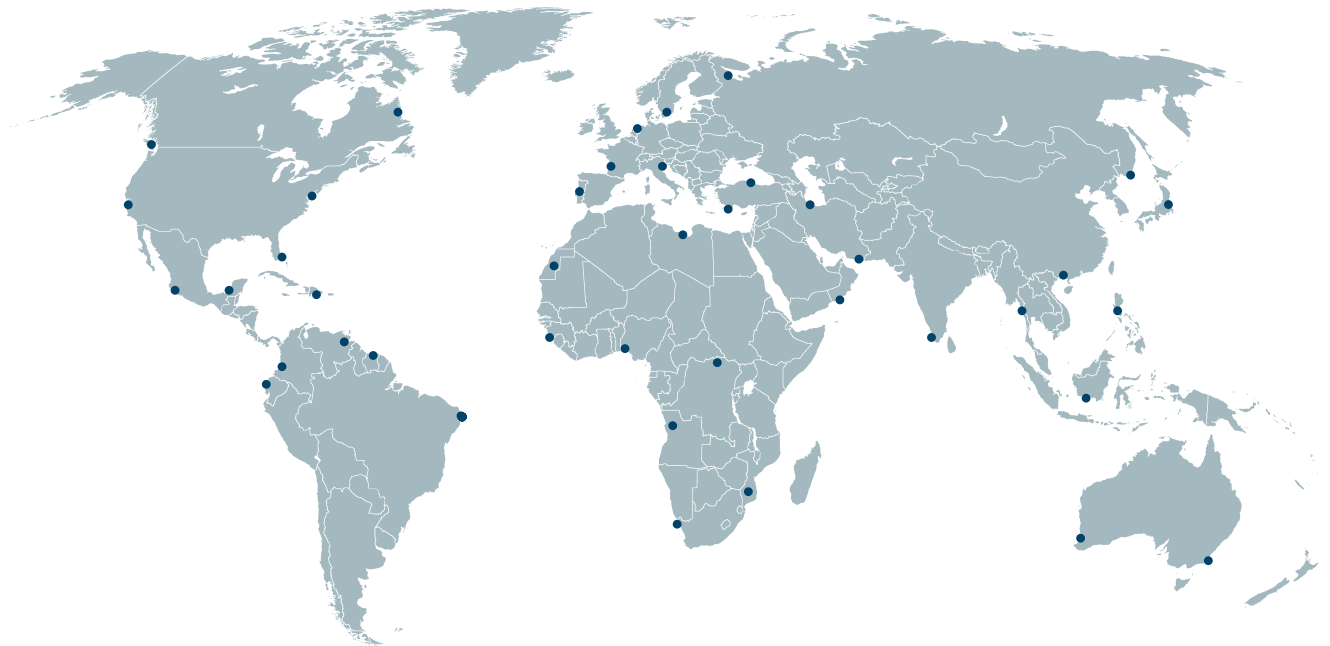

# EMCÉ

Winches | Stokvis Group

EMCÉ Winches

's Gravendamseweg 53b

2215 TC Voorhout - Holland

T. +31 252 214080

info@emce.com - www.emce.com

www.stokvis.eu

## Superior service in every part of the world

Our winches can only be superior if our services are too. EMCÉ winches are built to last and perform across the globe, under most severe conditions. Clients can rely on the outstanding quality of our products. If a winch needs to be commissioned, modified or examined, our worldwide network of dealers assures you of excellent support and maintenance. EMCÉ's stock and spare parts are globally available at short notice. Continuity of your business is therefore guaranteed. Anytime, anyplace. EMCÉ, every winch a winner.